

1/2OSP

SCALD PROTECTION VALVE



DESIGN FEATURES

- STAINLESS STEEL BODY
- STAINLESS STEEL AND BRASS INTERNAL COMPONENTS
- LONG LIFE SILICONE PLUG SEAL
- CORROSION RESISTANT
- OGONTZ THERMAL ACTUATOR
- MAXIMUM OPERATING PRESSURE 150 PSIG(10.3 BAR)

BENEFITS

- EASY INSTALLATION
- RELIABLE, UNATTENDED OPERATION
- MINIMUM MAINTENANCE
- PROVIDES EFFECTIVE SCALD PROTECTION

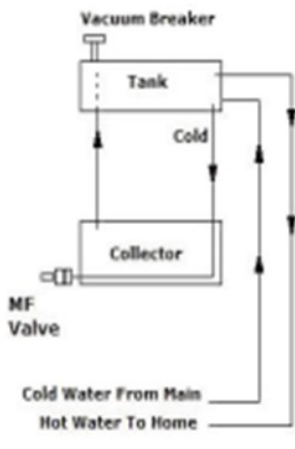

Thermosiphon System

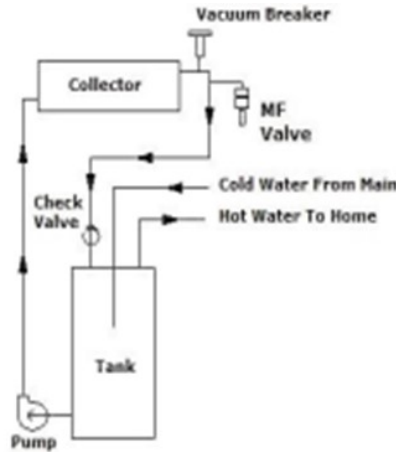

Active Open Loop

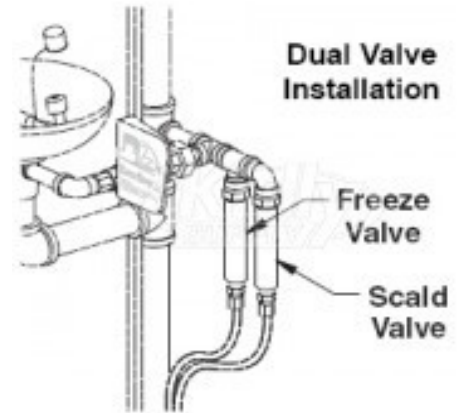

Valve Operation

Example: Model 1/2 OSP starts to close when water temperature is 100 F (37.8°C).

Differential from fully open to full close is typically 10 to 15° F. Valve opens/closes gradually.

Maximum Pressure psig (bar)	Maximum Temperature ° F (°C)	Cv	Weight Oz (g)
150 (10.3)	250 (121)	0.4	5.3 (150)

HOW TO ORDER



Temperature To Fully Open:

Specify Temperature of 100° F
(37.8° C) Or 110° F (43.3° C)

The Ogontz Guarantee: We will repair or replace on a no-charge basis, FOB Willow Grove, PA., any valve returned to us within 18 Months, if found to be defective in material or workmanship.

2835 Terwood Road · Willow Grove, PA 19090

800/523-2478 · 215/657-4770 · Fax: 215/657-0460

www.ogontz.com · info@ogontz.com

North America · South America · Europe · Asia

Copyright Ogontz Corporation, 2012 · Bulletin mf 5-12

